

B - MC/MQ STYLES

Single Reduction

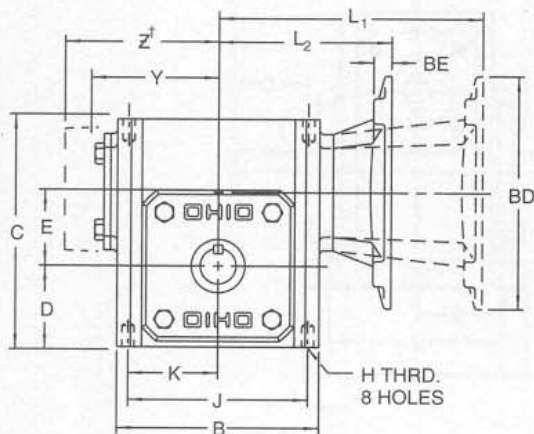

FRAMES 56C & 143-145TC

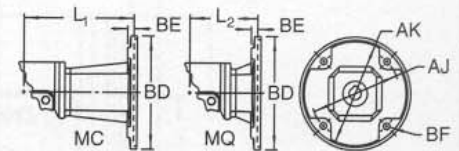
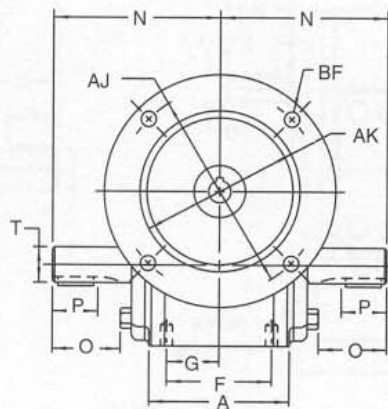

FRAMES 182-184TC, 213-215TC, & 254-256TC

ASSEMBLIES

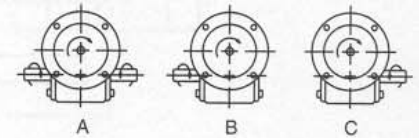

Shafts may be rotated either direction. Arrows merely indicate relative rotation. When ordering specify assembly desired.

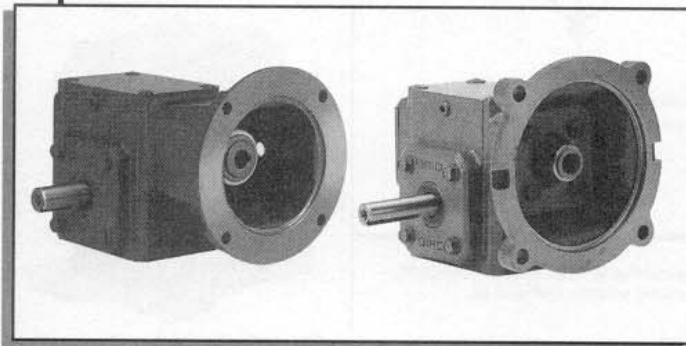

Motor Bell Dimensions

Frame	AJ	AK	BD	BE	BF	KEYWAY	Motor Shaft
56C	5.875	4.500	6.50	.50	.41	3/16 x 3/32	.625
143-145TC	5.875	4.500	6.50	.50	.41	3/16 x 3/32	.875
182-184TC	7.250	8.500	9.00	.56	.53	1/4 x 1/8	1.125
213-215TC	7.250	8.500	9.00	.56	.53	5/16 x 5/32	1.375
254-256TC	7.250	8.500	9.00	.58	.53	3/8 x 3/16	1.625

†Fans are optional for units 2300 through 2525.
Fans included on units 1600 and up.



Unit	A	B	C	D	E	F	G	H	J	K	Y	Z
2133	2.75	4.00	4.66	1.72	1.33	2.00	1.00	5/16-18	3.25	1.63	2.56	-
2175	3.82	5.00	5.75	2.06	1.75	2.75	1.38	5/16-18	4.19	2.09	3.15	-
2206	3.94	5.62	6.38	2.28	2.06	2.88	1.44	3/8-16	5.00	2.50	3.46	-
2238	4.18	6.26	6.94	2.50	2.38	2.88	1.44	3/8-16	5.00	2.50	3.68	-
2262	4.56	7.26	8.00	2.94	2.62	3.38	1.69	3/8-16	6.38	3.19	4.24	-
2300	5.06	8.26	8.88	3.25	3.00	4.00	2.00	7/16-14	7.00	3.50	4.87	6.34
2325	6.06	8.54	9.38	3.50	3.25	4.00	2.00	7/16-14	7.50	3.75	4.93	6.40
2425	6.56	11.00	12.00	4.44	4.25	5.00	2.50	5/8-11	9.50	4.75	6.30	8.15
2525	7.50	13.00	14.00	5.31	5.25	5.81	2.91	5/8-11	11.00	5.50	7.30	9.15
1600	8.12	14.50	16.50	6.50	6.00	6.38	3.19	5/8-11	12.76	6.38	8.35	11.50
1700	7.64	15.36	18.94	7.58	7.00	5.50	2.75	1-8	12.50	6.25	-	11.36
1800	8.64	17.36	21.20	8.86	8.00	6.50	3.25	1-8	14.25	7.13	-	12.32

Unit	Low Speed Shaft					56C				56C			
	N	O	P	T	KEY	140TC	180TC	210TC	250TC	140TC	180TC	210TC	250TC
						L1 (MC)				L2 (MQ)			
2133	4.00	1.89	1.50	.625	3/16 x 3/16	5.94	-	-	-	*3.96	-	-	-
2175	4.31	1.63	1.25	.875	3/16 x 3/16	7.00	-	-	-	4.44	-	-	-
2206	4.69	1.95	1.35	1.000	1/4 x 1/4	7.31	-	-	-	4.75	-	-	-
2238	5.09	2.25	1.56	1.125	1/4 x 1/4	8.00	8.56	9.19	-	5.06	5.22	-	-
2262	5.63	2.60	2.03	1.125	1/4 x 1/4	8.56	9.13	9.75	-	5.62	5.78	-	-
2300	6.75	3.38	2.88	1.250	1/4 x 1/4	9.19	9.75	10.38	-	6.25	6.41	-	-
2325	7.06	3.25	2.88	1.375	5/16 x 5/16	9.25	9.81	10.44	-	6.31	6.47	-	-
2425	8.06	3.79	3.50	1.750	3/8 x 3/8	11.83	12.77	12.77	12.99	6.77	7.21	7.21	7.86
2525	9.06	4.30	4.00	2.000	1/2 x 1/2	13.21	14.25	14.25	14.96	8.14	8.58	8.58	9.23
1600	10.00	4.66	4.00	2.500	5/8 x 5/8	-	15.53	15.53	16.18	8.88	9.32	9.32	9.94
1700	11.76	4.84	4.00	2.750	5/8 x 5/8	-	14.90	14.90	14.90	-	-	-	-
1800	12.26	5.38	4.50	3.000	3/4 x 3/4	-	-	15.88	15.88	-	-	-	-

* Only available in 56C frame; not available in 140TC frame size.